



POE POWER SUPPLY

- AC 100-240V Wide-range input
- Width only 77mm
- 8x 30W ports (acc.to IEEE 802.3at)
- Data transfer rate 1000Mbps
- Temperature range -25°C and +70°C
- Plug & Play installation and DIN rail mounting
- 3 Year Warranty

GENERAL DESCRIPTION

The POE.8AT-AC1 is a DIN-rail mountable single-phase-input power supply, which provides power for Power over Ethernet (PoE) applications. It injects power to 8 individual PoE channels (IEEE 802.3at) via RJ45 Ethernet ports. The device can supply powered devices PD of type1 and type2.

SHORT-FORM DATA

AC Input voltage range	AC 100-240V	Suitable for TN-, TT- and ITIT ains networks
DC Output voltage range	48 – 56Vdc	Factory setting 56V
Output power channels	8x 30W 8x 22.5W	Below +60°C ambient At +70°C ambient Derate linearly between +60°C and +70°C
Output current limitation	0.63A 0.47A	Below +60°C ambient At +70°C ambient
Efficiency	95.4%	At 230Vac
Losses	11.3W	At 230Vac
Temperature range	-25°C to +70°C	
Size (wxhxd)	77x128x117mm	Without DIN-Rail
Weight	900g / 1.98 lb	

ORDER NUMBERS

PoE Power Supply **POE.8AT-AC1**

Mechanical Accessory ZM10.WALL
Wall/panel mount bracket

MARKINGS



INDEX

	Page		Page
1. Intended Use	3	16. Protection Features	13
2. Installation Requirements	3	17. Safety Features	13
3. AC-Input	4	18. Dielectric Strength	14
4. DC-Input	5	19. Approvals	15
5. Input Inrush Current	6	20. Other Fulfilled Standards	15
6. Output	6	21. Physical Dimensions and Weight	16
7. Hold-up Time	7	22. Accessories	17
8. DC-OK Relay Contact	7	22.1. ZM10.WALL – Wall/Panel Mount Bracket	17
9. Efficiency and Power Losses	8	23. Application Notes	18
10. Lifetime Expectancy and MTBF	8	23.1. External Input Protection	18
11. Functional Diagram	9	23.2. Operation on Two Phases	18
12. Terminals and Wiring	9	23.3. Use in a Tightly Sealed Enclosure	18
13. Front Side and User Elements	10	23.4. Mounting Orientations	19
14. EMC	11		
15. Environment	12		

The information given in this document is correct to the best of our knowledge and experience at the time of publication. If not expressly agreed otherwise, this information does not represent a warranty in the legal sense of the word. As the state of our knowledge and experience is constantly changing, the information in this data sheet is subject to revision. We therefore kindly ask you to always use the latest issue of this document (available under www.pulspower.com).

No part of this document may be reproduced or utilized in any form without our prior permission in writing.

TERMINOLOGY AND ABBREVIATIONS

PE and \oplus symbol	PE is the abbreviation for Protective Earth and has the same meaning as the symbol \oplus .
Earth, Ground	This document uses the term “earth” which is the same as the U.S. term “ground”.
T.b.d.	To be defined, value or description will follow later.
AC 230V	A figure displayed with the AC or DC before the value represents a nominal voltage with standard tolerances (usually $\pm 15\%$) included. E.g.: DC 12V describes a 12V battery disregarding whether it is full (13.7V) or flat (10V)
230Vac	A figure with the unit (Vac) at the end is a momentary figure without any additional tolerances included.
50Hz vs. 60Hz	As long as not otherwise stated, AC 100V and AC 230V parameters are valid at 50Hz mains frequency. AC 120V parameters are valid for 60Hz mains frequency.
may	A key word indicating flexibility of choice with no implied preference.
shall	A key word indicating a mandatory requirement.
should	A key word indicating flexibility of choice with a strongly preferred implementation.

1. INTENDED USE

This device is designed for installation in an enclosure and is intended for commercial use, such as in industrial control, process control, monitoring and measurement equipment or the like.

Do not use this device in equipment where malfunction may cause severe personal injury or threaten human life.

2. INSTALLATION REQUIREMENTS

This device may only be installed and put into operation by qualified personnel.

This device does not contain serviceable parts.

If damage or malfunction should occur during installation or operation, immediately turn power off and send unit to the factory for inspection.

This device is designed for convection cooling and does not require an external fan. Do not obstruct airflow and do not cover ventilation grid (e.g. cable conduits) by more than 15%!

Keep the following installation clearances: 40mm on top, 20mm on the bottom, 5mm on the left and right sides are recommended when the device is loaded permanently with more than 50% of the rated power. Increase this clearance to 15mm in case the adjacent device is a heat source (e.g. another power supply).

A disconnecting means shall be provided for the output of the power supplies when used in applications according to CSA C22.2 No 107.1-01.

 **WARNING** Risk of electrical shock, fire, personal injury or death.

- Do not use the injector without a proper grounded power supply (Protective Earth). It is recommended to ground power supply –pole with PE.
- Turn power off before working on the device. Protect against inadvertent re-powering.
- Make sure that the wiring is correct by following all local and national codes.
- Do not modify or repair the unit.
- Do not open the unit.
- Use caution to prevent any foreign objects from entering the housing.
- Do not use in wet locations or in areas where moisture or condensation can be expected.
- Do not touch during power-on, and immediately after power-off. Hot surfaces may cause burns.

3. AC-INPUT

AC input	Nom.	AC 100-240V	Suitable for TN-, TT- and IT mains networks
Allowed voltage L or N to earth	Max.	300Vac	Continuous according to IEC 62477-1
Input frequency	Nom.	50–60Hz	±6%
Turn-on voltage	Typ.	80Vac	Steady-state value, see Fig. 3-1
Shut-down voltage	Typ.	70Vac	Steady-state value, see Fig. 3-1
	Typ.	55Vac	Dynamic value for maximal 250ms
External input protection	See recommendations in chapter 23.1.		

		AC 100V	AC 120V	AC 230V	
Input current	Typ.	2.82A	2.32A	1.20A	At 48V, 5.4A, see Fig. 3-3
Power factor ^{*)}	Typ.	0.99	0.99	0.98	At 48V, 5.4A, see Fig. 3-4
Start-up delay	Typ.	300ms	290ms	240ms	See Fig. 3-2
Rise time	Typ.	64ms	64ms	64ms	At 48V, 5.4A const. current load, 0mF load capacitance, see Fig. 3-2
	Typ.	211ms	211ms	211ms	At 48V, 5.4A const. current load, 5mF load capacitance, see Fig. 3-2
Turn-on overshoot	Max.	200mV	200mV	200mV	See Fig. 3-2
External input protection	See recommendations in chapter 24.1				

*) The power factor is the ratio of the true (or real) power to the apparent power in an AC circuit.

**) The crest factor is the mathematical ratio of the peak value to RMS value of the input current waveform.

Fig. 3-1 Input voltage range

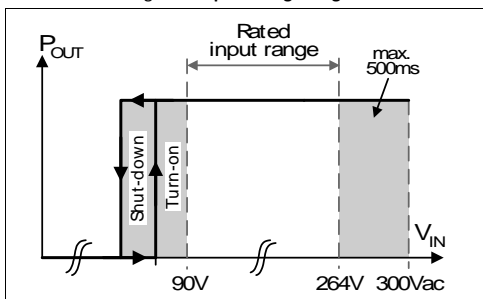

Fig. 3-3 Input current vs. output current at 48V output voltage

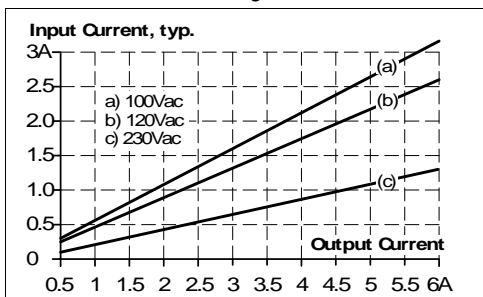

Fig. 3-2 Turn-on behavior, definitions

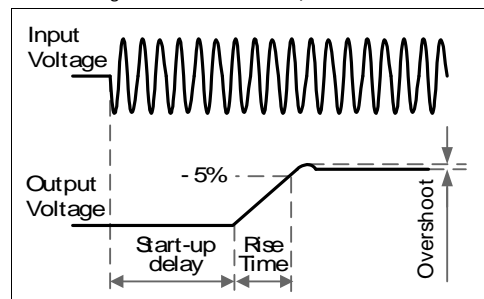

Fig. 3-4 Power factor vs. output current at 48V output voltage

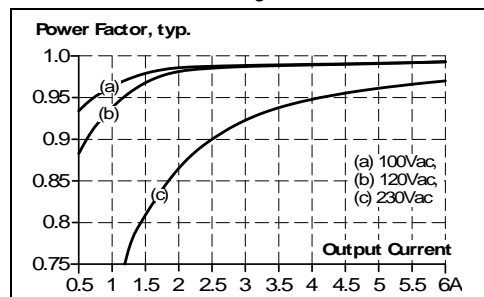
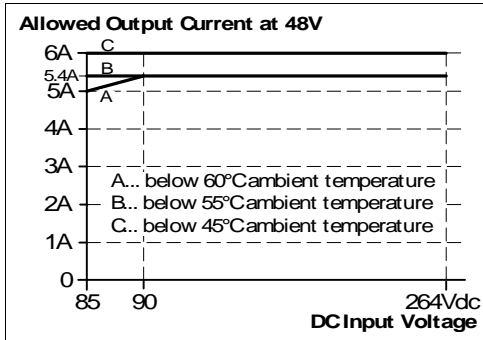

Fig. 3-5 Derating requirements



4. DC-INPUT

DC input	Nom.	DC 110-150V	±20%
DC input range	Min.	88-180Vdc	Continuous operation, Below 93.5Vdc, reduce output current according to Fig. 4-2.
DC input current	Typ.	2.51A	At 110Vdc
Allowed Voltage L/N to Earth	Max.	375Vdc	Continuous, according to IEC 62477-1
Turn-on voltage	Typ.	80Vdc	Steady state value
Shut-down voltage	Typ.	70Vdc	Steady state value
	Typ.	55Vdc	Dynamic value for maximal 250ms

Instructions for DC use:

- Use a battery or a similar DC source. A supply from the intermediate DC-bus of a frequency converter is not recommended and can cause a malfunction or damage the unit.
- Connect +pole to L and -pole to N.
- Connect the PE terminal to an earth wire or to the machine ground.

Fig. 4-1 Wiring for DC Input

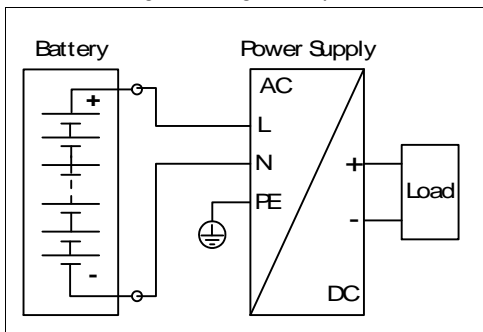
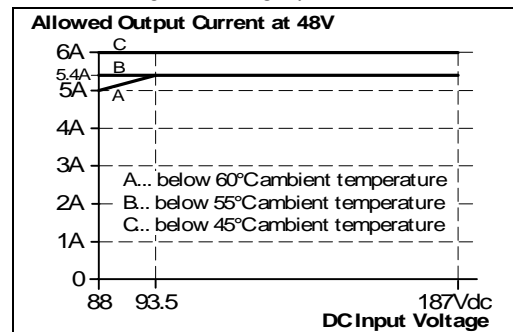

Fig. 4-2 Derating requirements



5. INPUT INRUSH CURRENT

An active inrush limitation circuit (NTCs, which are bypassed by a relay contact) limits the input inrush current after turn-on of the input voltage.

The charging current into EMI suppression capacitors is disregarded in the first microseconds after switch-on.

		AC 100V	AC 120V	AC 230V	
Inrush current	Max.	11A _{peak}	7A _{peak}	11A _{peak}	At 40°C, cold start
	Typ.	9A _{peak}	6A _{peak}	6A _{peak}	At 25°C, cold start
	Typ.	9A _{peak}	6A _{peak}	9A _{peak}	At 40°C, cold start
Inrush energy	Max.	0.1A ² s	0.1A ² s	0.4A ² s	At 40°C, cold start

Fig. 5-1 Typical turn-on behavior at nominal load, 120Vac input and 25°C ambient

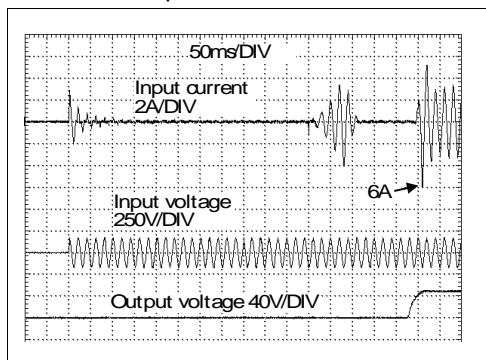
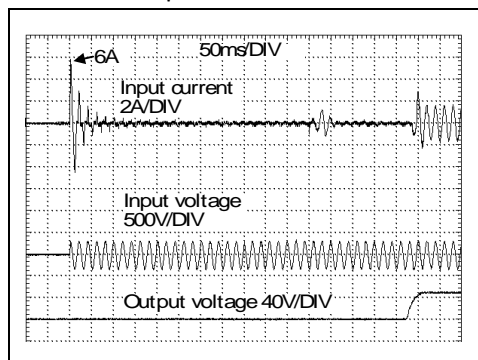

Fig. 5-2 Typical turn-on behavior at nominal load, 230Vac input and 25°C ambient



6. OUTPUT

Output voltage	Nom.	56V	
Adjustment range	Min.	48-56V	Guaranteed value
	Max.	58.0V	This is the maximum output voltage which can occur at the clockwise end position of the potentiometer due to tolerances. It is not a guaranteed value which can be achieved.
Factory settings	Typ.	56.0V	±0.2%, at full load and cold unit
Line regulation	Max.	10mV	Between 85 and 300Vac
Load regulation	Max.	50mV	Between 0 and 6A, static value, see Fig. 6-1
Ripple and noise voltage	Max.	50mVpp	Bandwidth 20Hz to 20MHz, 50Ohm
RJ45 Output channels		8x 30W	Below +60°C ambient
		8x 22.5W	At +70°C ambient
		Derate linearly between +60°C and +70°C	
Output current limitation		0.63A	Below +60°C ambient
		0.47A	At +70°C ambient

7. HOLD-UP TIME

		AC 100V	AC 120V	AC 230V	
Hold-up Time	Min.	50ms	50ms	50ms	At 48V, 2.7A, see Fig. 7-1
	Min.	26ms	26ms	26ms	At 48V, 5.4A, see Fig. 7-1

Fig. 7-1 Hold-up time vs. input voltage

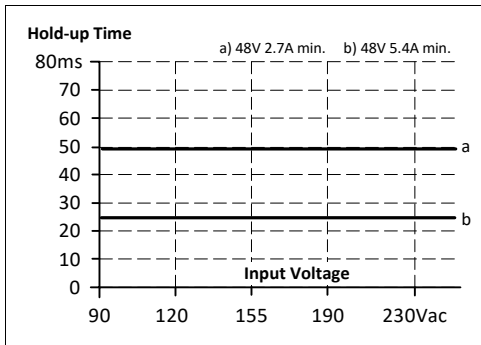
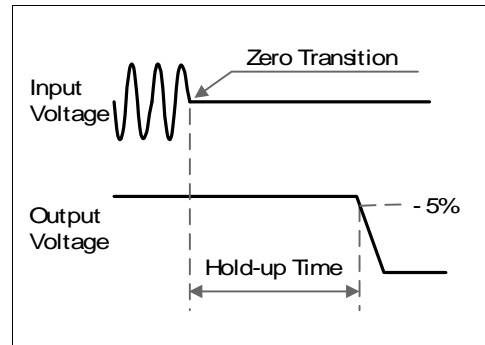

Fig. 7-2 Shut-down behavior, definitions



8. DC-OK RELAY CONTACT

This feature monitors the output voltage on the output terminals of a running power supply.

Contact closes	As soon as the output voltage reaches typ. 90% of the adjusted output voltage level.
Contact opens	As soon as the output voltage dips more than 10% below the adjusted output voltage. Short dips will be extended to a signal length of 100ms. Dips shorter than 1ms will be ignored.
Switching hysteresis	Typ. 2V
Contact ratings	Maximal 60Vdc 0.3A, 30Vdc 1A, 30Vac 0.5A, resistive load Minimal permissible load: 1mA at 5Vdc
Isolation voltage	See dielectric strength table in section 18.

Fig. 8-1 DC-ok relay contact behavior

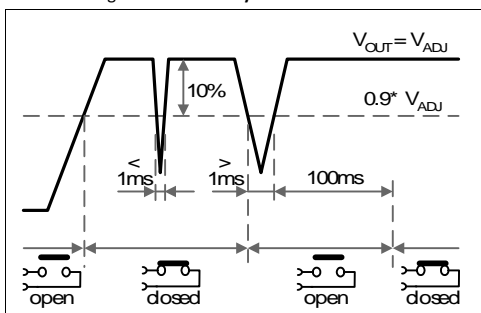

9. EFFICIENCY AND POWER LOSSES

		AC 100V	AC 120V	AC 230V	
Efficiency	Typ.	94.3%	94.6%	95.4%	at 8x 80W output
Power losses	Typ.	10.2W	9.5W	7.4W	at 8x 80W output

10. LIFETIME EXPECTANCY AND MTBF

The Lifetime expectancy shown in the table indicates the minimum operating hours (service life) and is determined by the lifetime expectancy of the built-in electrolytic capacitors. Lifetime expectancy is specified in operational hours and is calculated according to the capacitor's manufacturer specification. The manufacturer of the electrolytic capacitors only guarantees a maximum life of up to 15 years (131 400h). Any number exceeding this value is a calculated theoretical lifetime which can be used to compare devices.

	AC 100V	AC 120V	AC 230V	
Lifetime expectancy	141 000h	158 000h	188 000h	At 48V, 2.7A and 40°C
	399 000h	446 000h	531 000h	At 48V, 2.7A and 25°C
	63 000h	77 000h	120 000h	At 48V, 5.4A and 40°C
	178 000h	219 000h	338 000h	At 48V, 5.4A and 25°C
	45 000h	57 000h	97 000h	At 48V, 6A and 40°C
	126 000h	161 000h	275 000h	At 48V, 6A and 25°C

MTBF stands for **Mean Time Between Failure**, which is calculated according to statistical device failures, and indicates reliability of a device. It is the statistical representation of the likelihood of a unit to fail and does not necessarily represent the life of a product.

The MTBF figure is a statistical representation of the likelihood of a device to fail. A MTBF figure of e.g. 1 000 000h means that statistically one unit will fail every 100 hours if 10 000 units are installed in the field. However, it cannot be determined if the failed unit has been running for 50 000h or only for 100h. Please note, that MTBF values of the built in power supply are given here since these are the relevant figures:

	AC 100V	AC 120V	AC 230V	
MTBF SN 29500, IEC 61709	506 000h	523 000h	699 000h	At 48V, 5.4A and 40°C
	897 000h	923 000h	1 201 000h	At 48V, 5.4A and 25°C
MTBF MIL HDBK 217F	223 000h	224 000h	248 000h	At 48V, 5.4A and 40°C; Ground Benign GB40
	303 000h	303 000h	339 000h	At 48V, 5.4A and 25°C; Ground Benign GB25
	50 000h	51 000h	58 000h	At 48V, 5.4A and 40°C; Ground Fixed GF40
	65 000h	65 000h	74 000h	At 48V, 5.4A and 25°C; Ground Fixed GF25

11. FUNCTIONAL DIAGRAM

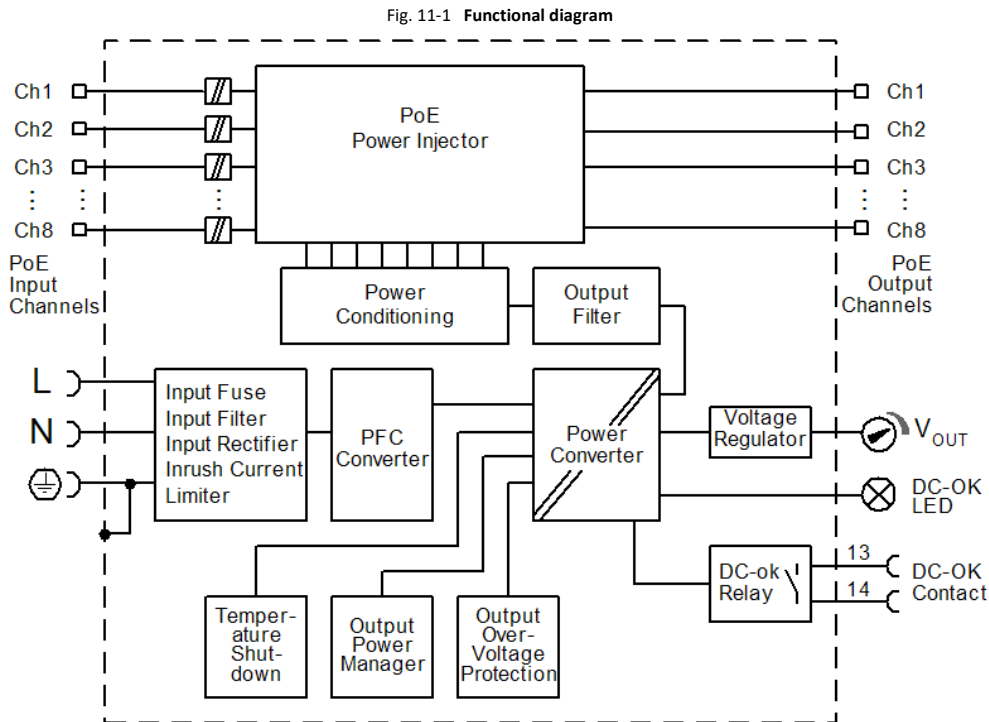

12. TERMINALS AND WIRING

The terminals are IP20 finger safe constructed and suitable for field- and factory wiring.

	Input	DC-OK-Signal
Type	Hot swap connector	Push-in terminals
Max. wire size (litz wire)	1.5mm ²	max. 1.5mm ²
Max. wire size with ferrules	1.5mm ²	max. 1.5mm ²
Wire size AWG	AWG 26-14	AWG 24-16
Maximum wire diameter	Max. 1.8mm	max.1.6mm (including ferrules)
Wire stripping length	6mm / 0.25inch	7mm / 0.28inch
Screwdriver	3.5mm slotted or cross-head No 2	not required
Recommended tightening torque	0.8Nm, 7lb.in	not applicable

Instructions:

- Use appropriate copper cables that are designed for minimum operating temperatures of:
 - 60°C for ambient up to 45°C and
 - 75°C for ambient up to 60°C minimum
 - 90°C for ambient up to 70°C minimum.
- Follow national installation codes and installation regulations!
- Ensure that all strands of a stranded wire enter the terminal connection!
- Unused terminal compartments should be securely tightened.

e) Ferrules are allowed.

13. FRONT SIDE AND USER ELEMENTS

Fig. 13-1
Front side



A	Power input terminal	Hot swap connector
B	Ethernet input	RJ45 jacks
C	Power-over-Ethernet output	RJ45 jacks
D	Output voltage potentiometer	Factory setting 56V
E	DC-OK LED (green)	ON when the output voltage is >90% of the adjusted output voltage
F	DC-ok relay contact	Hot swap connector

14. EMC

The power supply is suitable for applications in industrial environment as well as in residential, commercial and light industry environments.

EMC Immunity	According to generic standards: EN 61000-6-1 and EN 61000-6-2			
Electrostatic discharge	EN 61000-4-2	Contact discharge	±4kV	Criterion B
		Air discharge	±8kV	Criterion B
Electromagnetic RF field	EN 61000-4-3	80MHz-1GHz	10V/m	Criterion A
		1.4GHz-2GHz	3V/m	Criterion A
		2GHz-2.7GHz	1V/m	Criterion A
Fast transients (Burst)	EN 61000-4-4	AC Input lines	±2kV	Criterion B
		Data ports	±1kV	Criterion B
Surge voltage on input	EN 61000-4-5	L → N	±1kV	Criterion B
		L; N → PE	±2kV	Criterion B
Surge voltage on data input lines and PoE output lines	EN 61000-4-5	Data lines → PE	±0,5kV	Criterion B
Surge voltage on DC ok signal lines	EN 61000-4-5	DC ok signal → PE	±1kV	Criterion B
Conducted disturbance	EN 61000-4-6	0.15-80MHz	10V	Criterion A
Power Frequency Magnet Field	EN 61000-4-8	50Hz / 60Hz	30A/m	Criterion A
Mains voltage dips	EN 61000-4-11	0% of 100Vac	0Vac, 20ms	Criterion A
		40% of 100Vac	40Vac, 200ms	Criterion C
		70% of 100Vac	70Vac, 500ms	Criterion C
		0% of 200Vac	0Vac, 20ms	Criterion A
		40% of 200Vac	80Vac, 200ms	Criterion A
70% of 200Vac	140Vac, 500ms	Criterion A		
Voltage interruptions	EN 61000-4-11	0% of 200Vac (=0V)	5000ms	Criterion C

Criteria:

- A:** The PoE power supply shows normal operation behavior within the defined limits.
- B:** The PoE power supply operates as intended after the test. No degradation of performance or loss of function is allowed.
During the test, degradation of performance is however allowed. No change of actual operating state or stored data is allowed.
- C:** Temporary loss of function is possible. PoE Power supply may shut-down and restarts by itself. No damage or hazards for the PoE power supply will occur.

EMC Emission	According to generic standards: EN 61000-6-3 and EN 61000-6-4	
Conducted emission input lines	EN 55011, EN 55022, EN 55032, FCC Part 15, CISPR 11, CISPR 22	Class B
Conducted emission on data ports (Input and PoE output lines)	EN 55032	Class B
Radiated emission	EN 55011, EN 55022, EN 55032	Class B
Harmonic input current	EN 61000-3-2	Class A fulfilled between 0A and 6A load Class C fulfilled between 2.5A and 6A load
Voltage fluctuations, flicker	EN 61000-3-3	Fulfilled ¹⁾

This device complies with FCC Part 15 rules.

Operation is subjected to following two conditions: (1) this device may not cause harmful interference, and (2) this device must accept any interference received, including interference that may cause undesired operation.

Switching Frequencies

PFC converter	110kHz	Fixed frequency
Main converter	84kHz to 140kHz	Output load dependent
Auxiliary converter	60kHz	Fixed frequency

15. ENVIRONMENT

Operational temperature ¹⁾	-25°C to +70°C (-13°F to 158°F)	Reduce output power according to Fig. 15-1
Storage temperature	-40°C to +85°C (-40°F to 185°F)	For storage and transportation
Output de-rating	1.9W/°C 6.5W/°C	Between +45°C and +60°C (113°F to 140°F) Between +60°C and +70°C (140°F to 158°F)
Humidity	5 to 95% r.h.	According to IEC 60068-2-30 Do not energize while condensation is present
Altitude	0 to 2000m (0 to 6 560ft) 2000 to 6000m (6 560 to 20 000ft)	Without any restrictions Reduce output power or ambient temperature, see Fig. 15-2.
Altitude de-rating	15W/1000m or 5°C/1000m	Above 2000m (6500ft), see Fig. 15-2
Over-voltage category	III II	According to IEC 62477-1 for altitudes up to 2000m According to IEC 62477-1 for altitudes from 2000m to 6000m
Audible noise	Some audible noise may be emitted from the power supply during no load, overload or short circuit.	

1) Operational temperature is the same as the ambient or surrounding temperature and is defined as the air temperature 2cm below the unit.

Fig. 15-1 Output current vs. ambient temp.

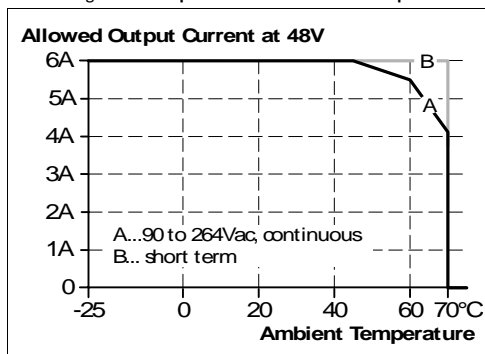
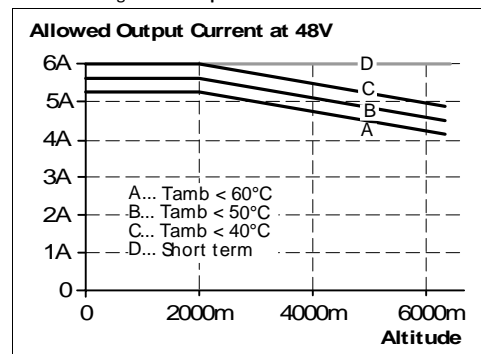

Fig. 15-2 Output current vs. altitude



16. PROTECTION FEATURES

Output protection	Electronically protected against overload, no-load and short-circuits. In case of a protection event, audible noise may occur.	
Output over-voltage protection	Typ. 58.5Vdc Max. 60Vdc	In case of an internal power supply defect, a redundant circuit limits the maximum output voltage. The output shuts down and automatically attempts to restart.
Degree of protection	IP 20	EN/IEC 60529
Penetration protection	> 4mm	E.g. screws, small parts
Over-temperature protection	Yes	Output shut-down with automatic restart. The temperature sensor is installed on critical components inside the unit and turns the unit off in safety critical situations (e.g. de-rating requirements not observed, high ambient temperature, ventilation obstructed or the mounting orientation de-rating is not followed). There is no correlation between the operating temperature and turn-off temperature since this is dependent on input voltage, load and installation methods.
Input transient protection	MOV (Metal Oxide Varistor)	For protection values see chapter 14 (EMC).
Internal input fuse	Included	Not user replaceable slow-blow high-braking capacity fuse

17. SAFETY FEATURES

Input / output separation	Double or reinforced galvanic isolation	
	SELV	IEC/EN 60950-1
	PELV	IEC/EN 60204-1, EN 62477-1, IEC 60364-4-41
Class of protection	I	PE (Protective Earth) connection required
Isolation resistance	> 500MΩ	At delivered condition between input and output, measured with 500Vdc
	> 500MΩ	At delivered condition between input and PE, measured with 500Vdc
	> 500MΩ	At delivered condition between output and PE, measured with 500Vdc
	> 500MΩ	At delivered condition between output and DC-OK contacts, measured with 500Vdc
PE resistance	< 0.10Ω	Resistance between PE terminal and the housing in the area of the DIN-rail mounting bracket.
Touch current (leakage current)	Typ. 0.14mA / 0.36mA	At 100Vac, 50Hz, TN-,TT-mains / IT-mains
	Typ. 0.20mA / 0.50mA	At 120Vac, 60Hz, TN-,TT-mains / IT-mains
	Typ. 0.33mA / 0.86mA	At 230Vac, 50Hz, TN-,TT-mains / IT-mains
	Max. 0.18mA / 0.43mA	At 110Vac, 50Hz, TN-,TT-mains / IT-mains
	Max. 0.26mA / 0.61mA	At 132Vac, 60Hz, TN-,TT-mains / IT-mains
	Max. 0.44mA / 1.05mA	At 264Vac, 50Hz, TN-,TT-mains / IT-mains

18. DIELECTRIC STRENGTH

The output voltage is floating and has no ohmic connection to the ground. Type and factory tests are conducted by the manufacturer. Field tests may be conducted in the field using the appropriate test equipment which applies the voltage with a slow ramp (2s up and 2s down). Connect all input-terminals together as well as all output poles before conducting the test. When testing, set the cut-off current settings to the value in the table below.

Fig. 18-1 Dielectric strength

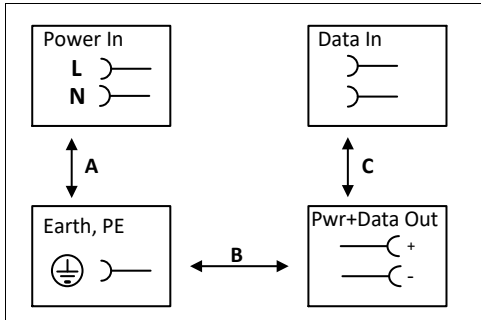

		A	B	C
Type test	60s	2500Vac	1500Vac	1000Vac
Factory test	5s	2500Vac	1500Vac	500Vac
Field test	5s	2000Vac	1500Vac	500Vac
Cut-off current setting		> 10mA	> 10mA	> 20mA

19. APPROVALS

EC Declaration of Conformity



The CE mark indicates conformance with the
- EMC directive,
- Low-voltage directive (LVD)

UL 61010
(planned)



Listed as Open Type Device
for use in Control Equipment
UL Category NMTR, NMTR7
E-File: E198865

EAC TR Registration



Registration for the Eurasian Customs Union market
(Russia, Kazakhstan, Belarus)

20. OTHER FULFILLED STANDARDS

RoHS Directive



Directive 2011/65/EU of the European Parliament and the Council of June 8th, 2011 on the restriction of the use of certain hazardous substances in electrical and electronic equipment.

REACH Directive



Directive 1907/2006/EU of the European Parliament and the Council of June 1st, 2007 regarding the Registration, Evaluation, Authorisation and Restriction of Chemicals (REACH)

IEC/EN 61558-2-16
(Annex BB)

Safety Isolating Transformer

Safety Isolating Transformers corresponding to Part 2-6 of the IEC/EN 61558

21. PHYSICAL DIMENSIONS AND WEIGHT

Width	77mm 3,03" 128mm 5,06"
Depth	117mm 4.61" The DIN-rail height must be added to the unit depth to calculate the total required installation depth.
Weight	900g / 1.98lb
DIN-Rail	Use 35mm DIN-rails according to EN 60715 or EN 50022 with a height of 7.5 or 15mm.
Housing material	Body: Aluminium alloy Cover: zinc-plated steel
Installation clearances	See chapter 2

Fig. 21-1
Front view

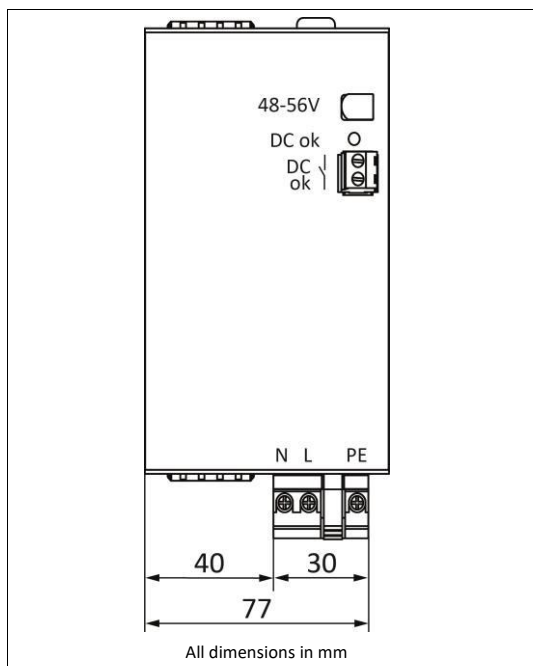
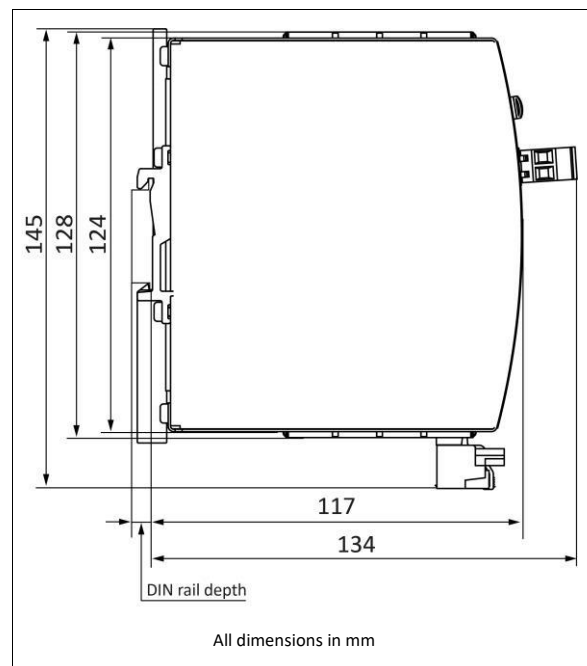

Fig. 21-2
Side view



22. ACCESSORIES

22.1. ZM10.WALL – WALL/PANEL MOUNT BRACKET

This bracket is used to mount the devices on a wall/panel without utilizing a DIN-Rail. The bracket can be mounted without detaching the DIN-rail brackets.

Fig. 22-1 Isometric view

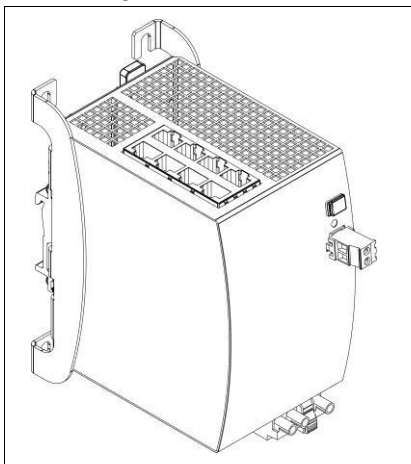

Fig. 22-2 Isometric view

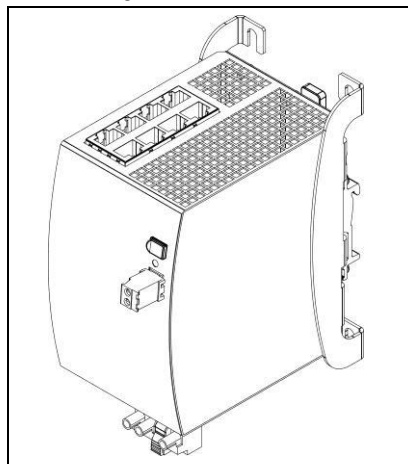

Fig. 22-3 Isometric view

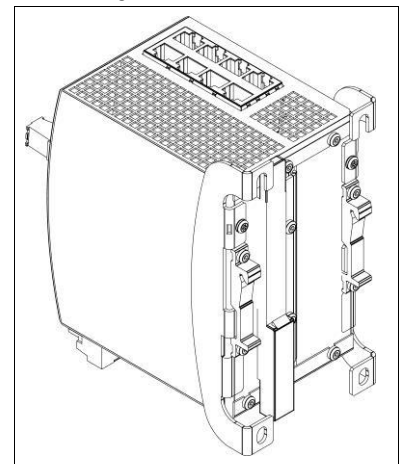

Fig. 22-4 Wall/panel mounting, front view

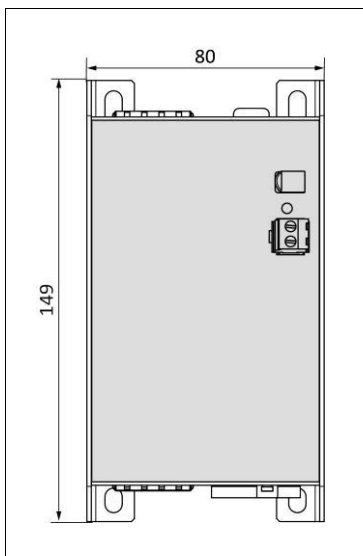

Fig. 22-5 Hole pattern for wall mounting

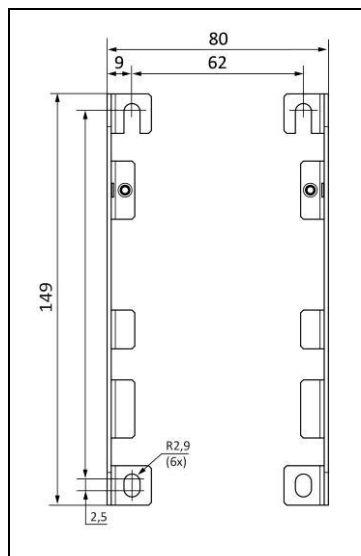
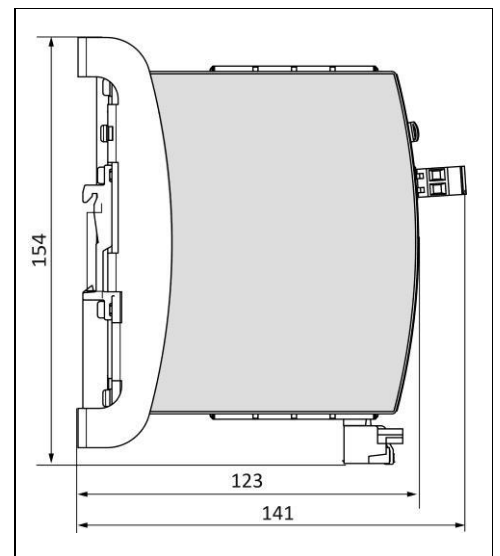

Fig. 22-6 Wall/panel mounting, side view



23. APPLICATION NOTES

23.1. EXTERNAL INPUT PROTECTION

The unit is tested and approved for branch circuits up to 30A (UL) and 32A (IEC). An external protection is only required if the supplying branch has an ampacity greater than this. Check also local codes and local requirements. In some countries local regulations might apply.

If an external fuse is necessary or utilized, minimum requirements need to be considered to avoid nuisance tripping of the circuit breaker. A minimum value of 6A B- or C-Characteristic breaker should be used.

23.2. OPERATION ON TWO PHASES

The power supply can also be used on two-phases of a three-phase-system. Such a phase-to-phase connection is allowed as long as the supplying voltage is below 240V^{+10%}.

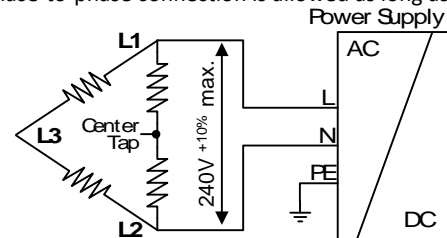

23.3. USE IN A TIGHTLY SEALED ENCLOSURE

When the power supply is installed in a tightly sealed enclosure, the temperature inside the enclosure will be higher than outside. In such situations, the inside temperature defines the ambient temperature for the power supply.

The following measurement results can be used as a reference to estimate the temperature rise inside the enclosure.

The power supply is placed in the middle of the box, no other heat producing items are inside the box

The temperature sensor inside the box is placed in the middle of the right side of the power supply with a distance of 1cm.

	Case A	Case B	Case C	Case D
Enclosure size	110x180x165mm Rittal Typ IP66 Box PK 9516 100, plastic	110x180x165mm Rittal Typ IP66 Box PK 9516 100, plastic	180x180x165mm Rittal Typ IP66 Box PK 9519 100, plastic	180x180x165mm Rittal Typ IP66 Box PK 9519 100, plastic
Input voltage	230Vac	230Vac	230Vac	230Vac
Load	48V, 4.3A; (=80%)	48V, 5.4A; (=100%)	48V, 4.3A; (=80%)	48V, 5.4A; (=100%)
Temperature inside the box	43.7°C	48.6°C	40.9°C	45.0°C
Temperature outside the box	24.1°C	25.4°C	23.9°C	25.0°C
Temperature rise	19.6K	23.2K	17.0K	20.0K

23.4. MOUNTING ORIENTATIONS

Mounting orientations other than all terminals on the bottom require a reduction in continuous output power or a limitation in the maximum allowed ambient temperature. The amount of reduction influences the lifetime expectancy of the power supply. Therefore, two different derating curves for continuous operation can be found below:

Curve A1 Recommended output current.

Curve A2 Max allowed output current (results in approximately half the lifetime expectancy of A1).

Fig. 23-1
Mounting
Orientation A
(Standard
orientation)

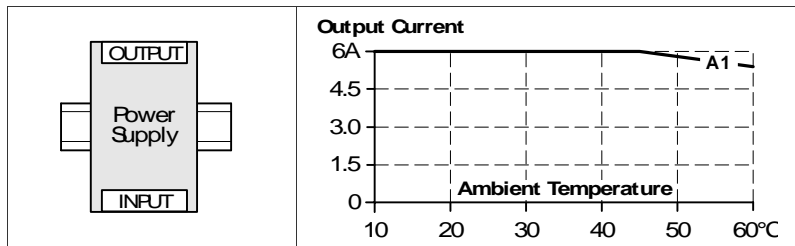

Fig. 23-2
Mounting
Orientation B
(Upside down)

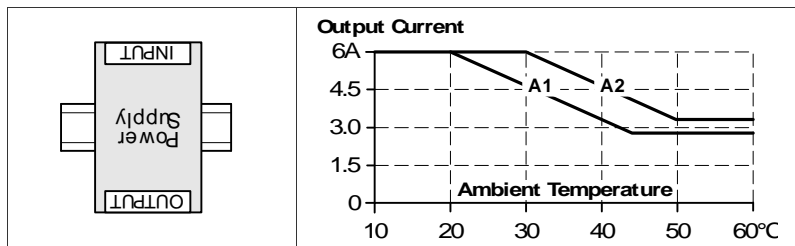

Fig. 23-3
Mounting
Orientation C
(Table-top
mounting)

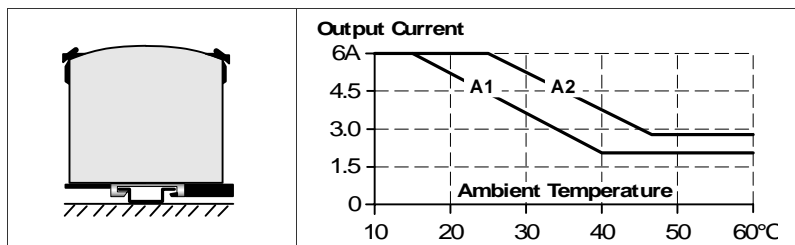

Fig. 23-4
Mounting
Orientation D
(Horizontal cw)

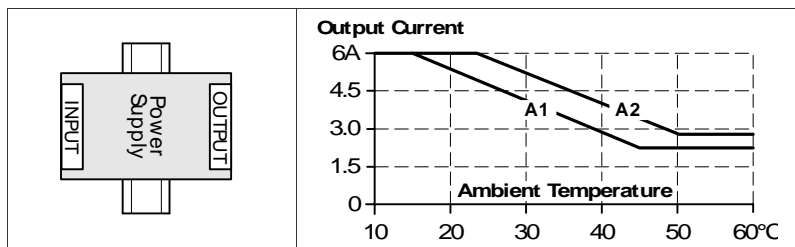

Fig. 23-5
Mounting
Orientation E
(Horizontal ccw)

